



SAILOR A1 Basic VHF **Operating Instructions**

Distress Call, see page ii. Contents, see page 1.

DISTRESS Call



1. If off or UNIT OFF: press ON/OFF.

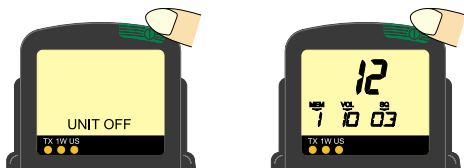

2. Hook off the handset.

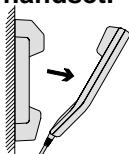

3. To enter VHF mode on CH 16 press

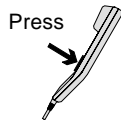
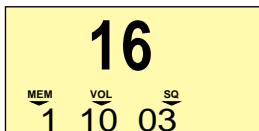

Pressing PTT, say:

“MAYDAY”

“This is”

- the 9-digit identity and the call sign or other identification of the ship,
- The ship's position,
- The nature of distress and assistance wanted,
- any other information which might facilitate the rescue.

“OVER.”

Release PTT and
listen for answer.



Handset

What is What?

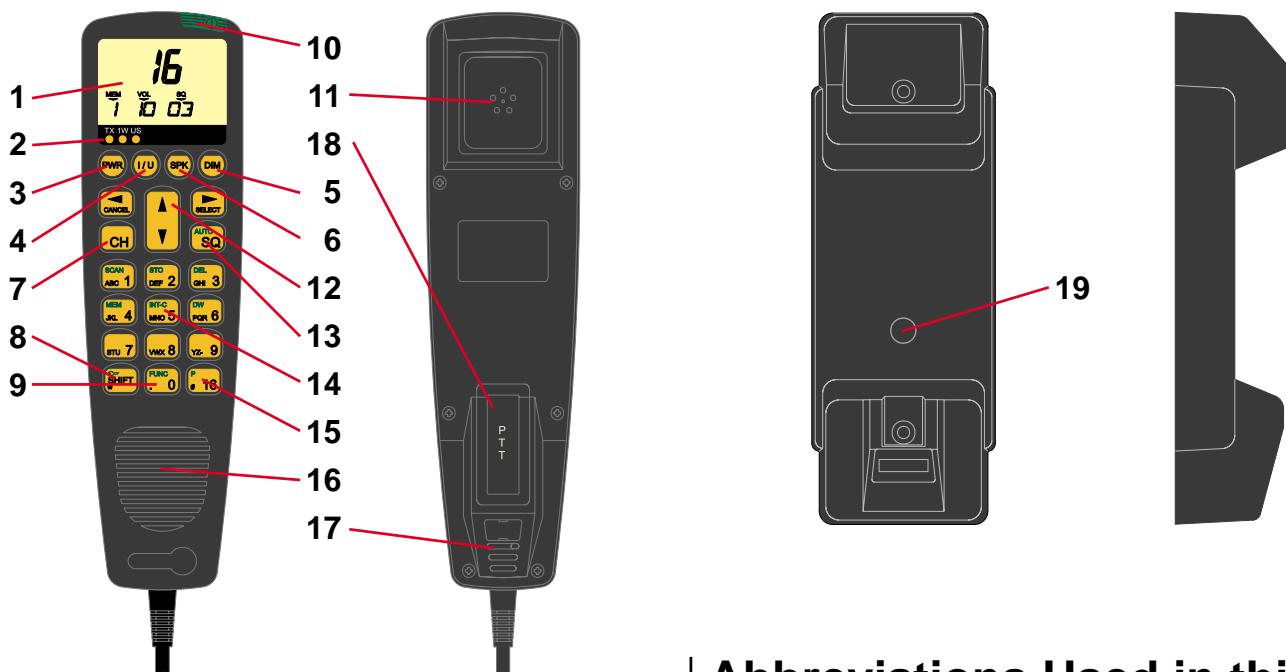

- | | |
|---|-----------------------------------|
| 1. Display | 9. FUNC key |
| 2. Indicator lamps
TX
1W
US | 10. ON/OFF button |
| 3. TX power level | 11. Earpiece |
| 4. INT/US (for information on
the BI version, see page 7.) | 12. Volume control |
| 5. Dimmer | 13. Squelch selection |
| 6. Speaker ON/OFF | 14. Intercom |
| 7. Channel selection | 15. Channel 16 quick select |
| 8. Shift key | 16. Loudspeaker |
| | 17. Microphone |
| | 18. PTT key |
| | 19. 25W key
(US versions only) |

Abbreviations Used in this Manual

ADDR	Address
ATIS	Automatic Transmitter Identification System
BI	Channel Mode used when sailing on European rivers (details on p. 7)
CU	Control Unit
DSC	Digital Selective Calling
DUP	Duplex
DW	Dual Watch
GMDSS	Global Maritime Distress and Safety System
GPS	Global Positioning System
LF	Low Frequency
MEM	Memory
MMSI	Maritime Mobile Service Identity
MSG	Message
PTT	Push-To-Talk (talk button)
RX	Receive(r)
SQ	Squelch
STN	Station
TEL	Telephony
TX	Transmit(ter)
UTC	Coordinated Universal Time

Introduction

For more than half a century, Sailor has been synonymous with high-quality maritime communication equipment.

When it comes to making use of the very latest technology, S. P. Radio is at the forefront. We are ready for the future, both technologically and commercially, and will continue to supply top-quality equipment for global communication in the years to come.

S. P. Radio's experience in maritime safety and communication is extensive; the company has built as many as 250,000 VHF units, mainly for the professional market. One of the main reasons for this huge success is continual product development, which makes it possible for us to offer products that are truly excellent in terms of quality, sturdiness, ease of operation, and compact design.

The SAILOR A1 Basic and A1 DSC are part of the new SAILOR System 4000. This is a full range of maritime communication equipment developed to increase safety and ease communication for all kinds of vessels: leisure boats, fishing vessels, cargo ships, and cruise liners.

As our central concern is fast and professional service, we have introduced the SAILOR Certified Service Centre (CSC) concept. This, we feel, is the ultimate way of ensuring a high level of service, continuously monitored and adjusted.

Today S. P. Radio is the leading VHF supplier in the world, represented in 90 countries around the world. Consequently we are able to service your SAILOR VHF equipment in the best way possible. No matter where.

About this Manual

This manual is for the daily user of the system. The manual includes two main sections, "basic" operation and "full" operation. The basic part offers a short easily-read description of the main functions; the full part offers elaborate descriptions of the functions of the product.

Please note

Any responsibility or liability for loss or damage in connection with the use of this product and the accompanying documentation is disclaimed. The information in this manual is furnished for informational use only, is subject to change without notice, may contain errors or inaccuracies, and represents no commitment whatsoever. This agreement is governed by the laws of Denmark.

Doc. No.: B4900GB0

Issue: H/0139



S.P. RADIO A/S • Porsvej 2 • PO Box 7071 • DK-9200 Aalborg SV • Denmark
Phone: +45 9634 6100 • Fax: +45 9634 6101 • Telex: 69789 SPRAD DK
E-mail: sailor@sailor.dk • Web: www.sailor.dk

Contents

DISTRESS Call	ii
Handset	iii
What is What?	iii
Abbreviations Used in this Manual	iii
Introduction	iv
About this Manual	iv
Telephony Display	2
Handset Main Function Keys	2
Basic Operation	3
Switching ON/OFF	3
Basic Telephony Operation	3
Listening for Telephony Calls	3
Receiving a Telephony Call	4
Making a Telephony Call	4
Channel Control	5
Squelch Control	5
Setting the Volume Level	6
Muting the Speaker	6
Setting Transmitter Power Level	6
Dimmer Function	6
Full Operation	7
Full VHF Telephony Operation	7
Setting Channel Mode	7
Setting International/US Channel Mode	7
Setting International/BI Channel Mode	7
25W Transmitter Power Level	7
Setting Memory Scan Table	8
Scanning of Channels	8
Dual Watch	10
Keyboard Lock	11
Intercom	11
Function Menu	13
Function Menu Item Description	15
FUNCTION Menu Tree	17
VHF System Description	18
International Channels	19
US Channels	20
BI Channels	21

Telephony Display

Normal display

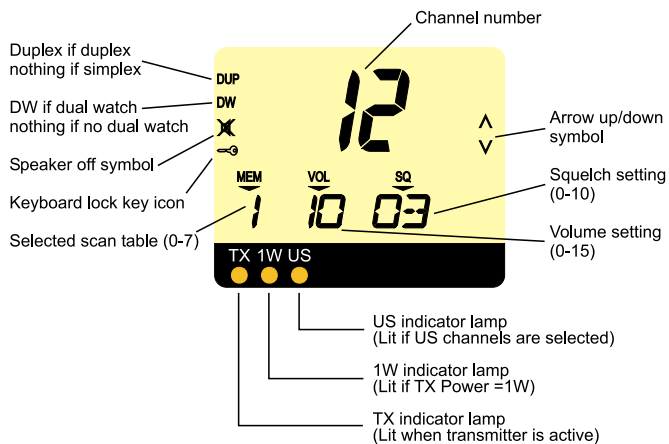

Scanning display

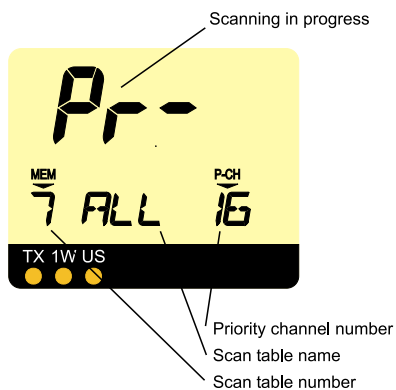

Handset Main Function Keys

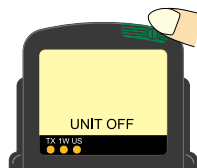

ON/OFF key.

Turns the handset on or off.



"16" key.

Selects TELEPHONY mode and channel 16.



Function menu.

Enters the function menu to set up the handset and system.

If function menu is active it enters VHF telephony mode.

After 5 minutes of inactivity the handset will resume in telephony mode by default.

Basic Operation

Switching ON/OFF

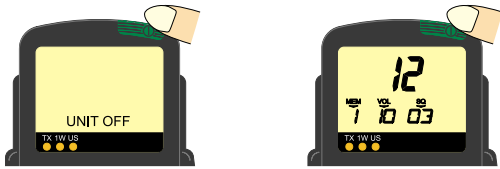

To switch on the handset unit, push the ON/OFF button on the handset.

If the handset unit is off, the display is blank or shows “UNIT OFF” to indicate that the system is operated from another control unit.

To switch off the handset unit, push the ON/OFF button on the handset for at least 1 second.

Basic Telephony Operation

To activate the VHF functions if not active press the key “16”.



Listening for Telephony Calls

According to international rules, all ships shall monitor channel 16 constantly:

1. Select channel 16 by pressing:

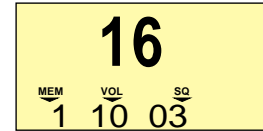

2. Set the squelch level by means of the buttons



- a. Step down squelch level until noise is heard on free channel.
- b. Then step up to the first level where just silent.

(To listen for calls on other channels, select the channel number or use the scanning facility.)

Receiving a Telephony Call

When a call comes in, and your call name is heard in the loud-speaker:

1. Hook off the handset.
2. Press the PTT key on the handset.

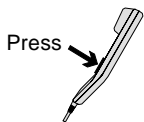

3. To answer the call, say:
“<The name of the calling station>
This is <Your station name>”

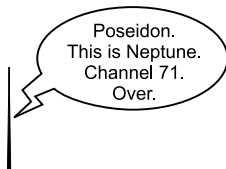

4. To suggest channel, say:
“Channel <suggested channel number>”

5. Say “over” and release the PTT key to let the caller accept the proposed channel number.



6. Switch to the channel agreed upon (for example channel 71) and communicate:



For short-distance communication, use 1W.

Press the PTT key when talking only. If on a simplex channel, say “over” every time you have completed talking.

Making a Telephony Call

In telephony mode:

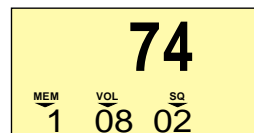

1. Select channel 16 or another channel specified or agreed upon:



2. Hook off the handset.

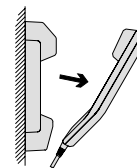

3. When speaking, press the handset PTT key.

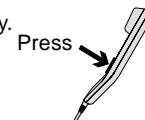

Make the call:

1. <Called station name (3 times)>
2. “This is “
<Your station name (3 times)>
3. “Over”

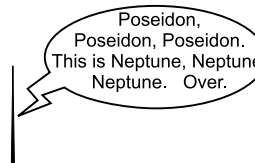

4. Release the PTT key to listen.



5. When answered, agree upon a channel, switch to the channel (for example channel 6) and communicate.



Press the PTT key when talking only. If on a simplex channel, say “over” every time you have completed talking.

Channel Control

Setting the VHF channel can be done in three ways by means of the numeric input keys (sequentially) or by means of the function “next channel up/down”, or by using the quick select key “16”:

Numeric keys:

Press the numeric input keys (sequentially) until the desired channel number is shown on the handset display:



Ex:

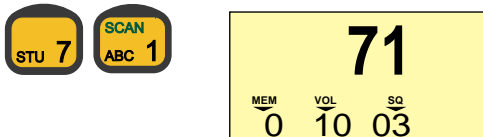

If private channels are available in your VHF system, a private channel number is selected by pushing the buttons:

Ex: Private channel 23

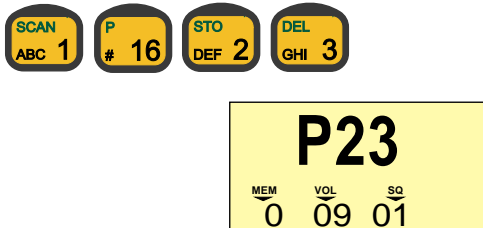

Next channel function:

To select the next channel up or down (starting point is displayed channel).

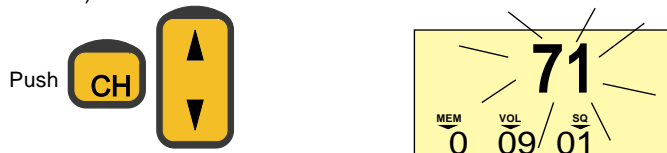

The next channel function is active until the key is released again, toggling through the channels as long as pushed.



Quick select key:

Press the key

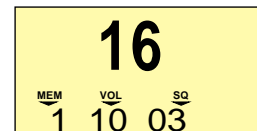

Squelch Control

Manual squelch level setting:

Set the squelch sensitivity of the receiver by buttons

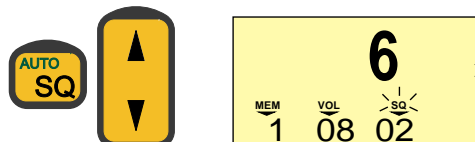

Press  for more than 4 seconds and the squelch level goes up/down automatically.

The squelch setting is shown on the display below the “SQ” symbol.

Automatic squelch level setting:

The VHF system automatically sets the optimal squelch level to mute the background noise level.

To set squelch level automatically:



Setting the Volume Level

Setting the volume level can be done both for the speaker and the earpiece individually. (The setting can be 0-15).

The volume level of the speaker can be controlled when handset is on hook, or the speaker is set to be active when handset is hooked off. The volume level of the earpiece can be controlled when the handset is hooked off, and the speaker is not set to be active when handset is hooked off. The volume setting for the earpiece can also be set in the function menu.

If the speaker is active the speaker setting is always shown on the display. Only when the handset is hooked off and the speaker is not set to be active, is the volume level of the earpiece shown.

To change the volume setting use

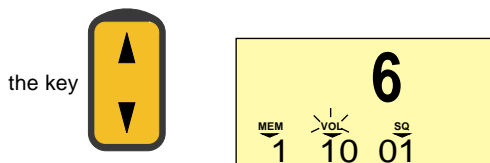

Press the key for more than 1 second and the volume level goes up/down automatically (until the volume limit is reached).

Muting the Speaker

If the speaker is active the handset automatically mutes the speaker when the PTT is pressed, and then reactivates the speaker when the PTT is released.

The speaker icon on the display shows the speaker state.

Speaker active:

To mute the speaker, press:

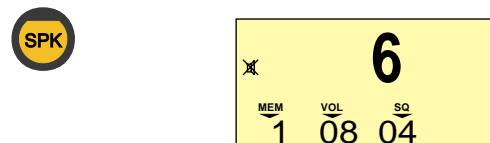

Speaker muted:

To reactivate the speaker, press:

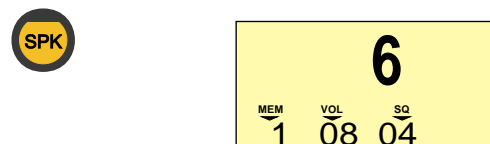

Setting Transmitter Power Level

The handset can control the transmitter power level, which can be set to either 1W or 25W.

Low power 1W is indicated by the indicator lamp on the display. Some channels may be programmed to operate at 1W level only.

To change the TX power level press .

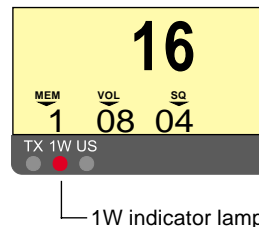

Dimmer Function

The handset features display backlight, keyboard backlight and light in the indicator lamps (TX, 1W, US). The light can be set at four steps 0-3.

To change the dimmer level:

Press 

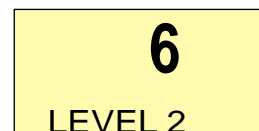

When the key is being pressed the dimmer level will change every second.

Full Operation

Full VHF Telephony Operation

Setting Channel Mode

Some VHF radios offer a choice between two sets of channels, called channel modes. If your VHF features two modes, you can either switch between international/US channels, or between international/BI channels.

International mode is used when sailing on any sea in the world, except in US waters.

US mode is used when sailing in US waters.

BI mode is used when sailing on the rivers of Europe.

Setting International/US Channel Mode

If your VHF features the choice of international/US mode, switching between those two sets of channels is done by pressing the key:

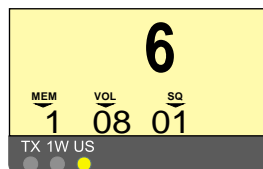

Channel mode indication

When US mode is selected, the yellow US indicator lamp is lit. Otherwise, the radio is in international mode.

Setting International/BI Channel Mode

If your VHF features the choice of international/BI mode, switching between those two sets of channels is done by pressing the key:

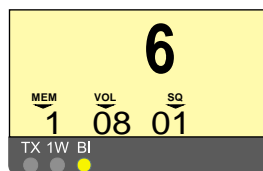

Channel mode indication

When BI mode is selected, the yellow BI indicator lamp is lit. Otherwise, the radio is in international mode.

When BI mode is selected, ATIS is activated automatically.

25W Transmitter Power Level

NB! For US channels 13 and 67.

If the VHF is programmed with the set of US channels, some of those channels are specified to be used only with the limited transmitter power level of 1W. This means that the TX power level cannot be changed to 25W as described.

However, it is still possible to set the TX power level to 25W by using:

The TX power level of 25W is only active while the key is being pressed down; when the key is released the TX power level is again reduced to 1W.

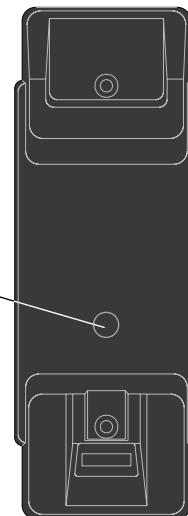

Setting Memory Scan Table

The VHF 4000 system has eight independent sets of memory tables to save channels for making scanning sessions. Each memory table may contain all channels available in the system.

To distinguish between the tables, each table has a number (0-7) and to each number can be attached a name of maximum seven characters.

To attach a name to a scan table, enter the function menu.

The scan table number selected is shown in the left corner of the handset display.

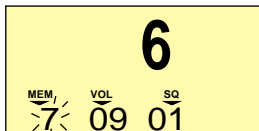

Pre-programmed memory tables for scanning of channels:

Table 6: Channels for intership communication.

Table 7: All channels in system.

It is recommended not to alter the pre-programmed channels in scanning tables 6 and 7. These scanning tables are used to search for channels for intership DSC communication, and altering the channels may exclude you from performing intership communication on certain channels.

Setting the selected scan table:

To set the selected scan table to be number 0:

1. Press  

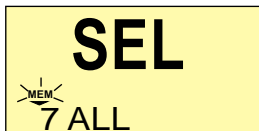

The handset display shows the message "SEL"ect and the MEM symbol flashes. The lower part of the display shows the scan table's number and name.

2. Press 

The display now shows the new scan table number 0.



Scanning of Channels

To start scanning:

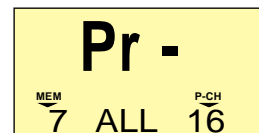

The lower part of the display shows from left to right: scan table number, scan table name, priority channel of scan table.

If scan table contains no channels, no scanning will be started, and the display will show the following message:

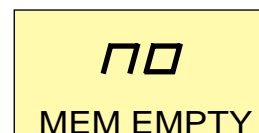

To stop scanning:

Scanning in progress can be terminated in the following ways:

1. Press  

The system resumes normal VHF operation on the channel selected before the scanning session was initiated.

2. Press 

The system resumes normal VHF operation on quick select channel "16".

3. Hook off the handset.

The system resumes normal VHF operation on the channel selected before the scanning session was initiated.

4. Push the PTT

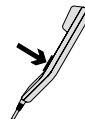

If no signal has been detected on any channel, the system resumes normal VHF operation on the channel selected before the scanning session was initiated. If a signal has been detected on a channel, the system resumes normal VHF on the last channel where signal was detected.

If scanning is in progress and a signal is detected on eg. channel 6, the display changes to show the selected channel number and volume level.

When a priority scanning is in progress, channel 16 is scanned once for every channel scanned in the scan table. Channel 16 cannot be deleted or excluded while a scanning is in progress.



To add a channel to a scan table:

Select channel number (shown on the display), and then press



Ex: To add channel 6 to scan table number 1:



Channel 6 is selected.

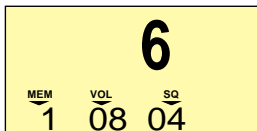

The message "stores channel" is shown for two seconds.



To delete a channel from a scan table:

Select channel number (shown on the display), and then



Ex: To delete channel 6 from scan table number 1:



Channel 6 is selected.



The message "delete channel" is shown for one second.

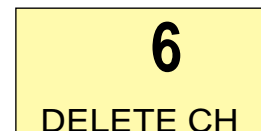

Then the display will show the next channel in the scan table.



If there are no more channels in the scan table and deletion is attempted, the display will show the message "mem empty".

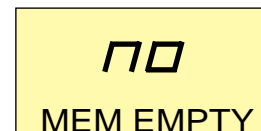

To view contents of channels in a scan table:

Viewing which channels a specific scan table contains, can be done in two ways:

While the key is being pressed down, the display will step through the channels of the scan table selected.

1. Press  , the latter for 1 second.

OR

2. Press  , the latter for 1 second.



Dual Watch

The handset may perform a dual watch of channels, a priority channel and the selected channel being monitored simultaneously.

To start a dual watch with channel 6 and priority channel 16:

Select channel 6.

Then press



When a dual watch is in progress, "DW" appears in the top left corner of the display and the priority channel is shown in the bottom right corner of the display.

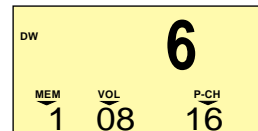

To stop a dual watch: When a dual watch is in progress it can be terminated in three ways.

1. Press  

2. Push PTT

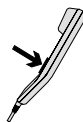

The system resumes VHF on the selected channel 6 and starts transmitting.

3. Push 





The system resumes VHF on the quick select channel (normally 16).

Keyboard Lock

The handset has a keyboard lock, which locks some keys to avoid unintentional channel changes during a telephony session. When the keyboard is locked the only functions that can be controlled are:

1. Setting the volume level.
2. Setting the squelch level.
3. Channel up/down.

To lock the keyboard:

Press   (second time, press for 1 second).

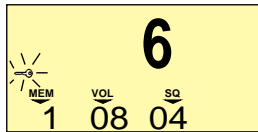

The key symbol appears, indicating that the keyboard is locked.

Unlocking the keyboard can be done in two ways:

1. Press  

The keyboard is unlocked.

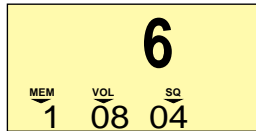

2. Press  # 16 for 1 second.

The keyboard is unlocked and channel 16 selected.



Intercom

If your VHF system has more than one control unit, it is possible to carry out an intercom between two control units. When the intercom feature is used the handset will perform as follows:

Initiating an intercom from the handset to another control unit:
To call another control unit:

1. Press  

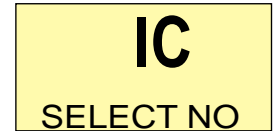

This display indicates that the handset expects an input of the location number to be called.

2. Press a numeric key to choose location to be called

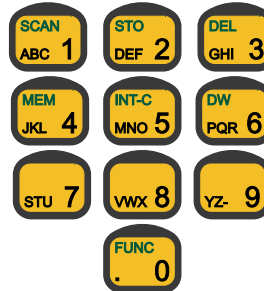

Ex: 

3. If location 2 is NOT available, the display shows

and no dialling is carried out.



If location 2 is available the display shows

and a ringing tone is heard in the speaker/earpiece.



This indicates that a dial-up is in progress to the control unit with location number 2. The lower part of the display now toggles the message CALLING and the NAME of the called control unit. During the dialling time of 30 seconds it is possible to hook off the handset and speak into the microphone. As LF is activated in the called control unit during dialling, the receiver of the call can hear you in the speaker without hooking off. This makes it possible to use the VHF system as a sort of paging system.

4. If the intercom attempt is answered:
When the receiver of the call hooks off his handset, the intercom is established.

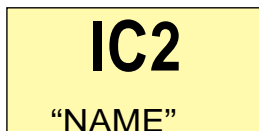

If the intercom attempt is not answered:
If the receiver of the call does not answer the intercom within 30 seconds, the handset automatically hangs up and reenters normal VHF operation.

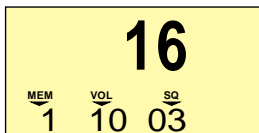

Receiving an intercom attempt from another control unit:

When an intercom is attempted from another control unit to the handset, this will act as illustrated in the following example, where the caller has location number 3.

1. Receiving an intercom

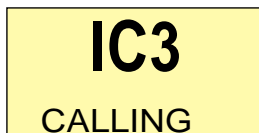

The display toggles CALLING and the NAME of the caller. A ringing tone is heard in the speaker.

2. To answer the intercom, hook off handset.

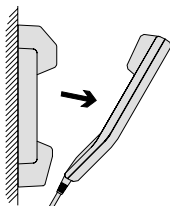

The intercom connection between the two control units is now established; to communicate, simply press PTT and speak into the microphone.

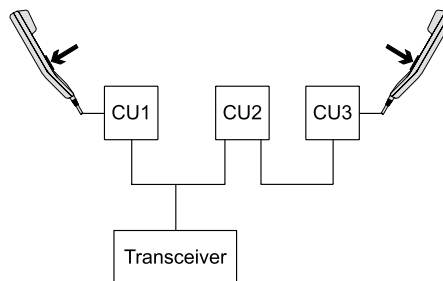

During intercom the handset is able to:

1. Adjust volume level



2. Mute/unmute speaker



3. Adjust squelch level



4. Adjust dimmer level



Terminating an intercom session:

The intercom connection can be terminated by either of the control units.

To end an intercom:

1. Place handset on hook.
The handset resumes in VHF mode.

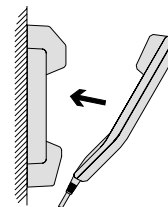

2. Key

The handset resumes in VHF mode.

3. Key

The handset resumes in VHF mode selecting channel "16".

Function Menu



The function menu offers facilities to view and set up the functionality of the handset unit. It also offers facilities to view and change functionality of the VHF transceiver and of the DSC modem as well.

To enter the function menu.

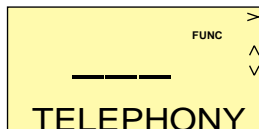

To view or set any specific items in the function menu press the keys



To move around in the function menu use the keys:

1.  : To set menu entry to be entered.
2.  : To enter the entry set in 1.
3.  : To reenter the function menu (press for 1 second).

To edit items in the function menu, use the keys:

1.  :
 - a. To change option "Y"/"N".
 - b. To change single numeric value, up or downwards until limit.
2.  :
 - a. To save/select item setting, entering the next item too.
 - b. To move one step to the right in an item with more inputs.
3.  :
 - a. To reenter the function menu (press for 1 second).
 - b. To delete the character to the left of the cursor (moving one step to the left in an item).

4.

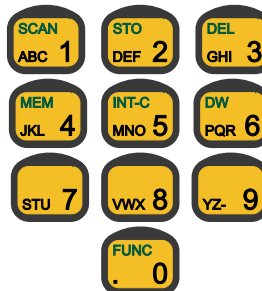

- a. To enter an alphanumeric character in the cursor's place.

To leave the function menu:

NB: If any setting has been changed when leaving the function menu, the handset has to be turned off and then on again for the changes to take effect.

The function menu can be left in the following ways:

1.  : Activates VHF mode, selecting channel 16

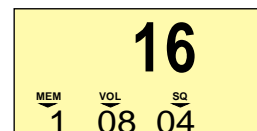

2.  : Activates VHF mode

Example:

To activate keyboard "beep" function for keyboard to beep every time a key is pressed.



Enters the function menu

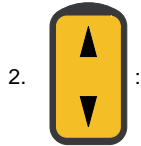
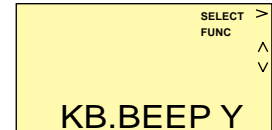
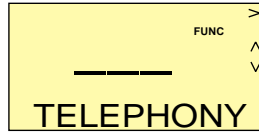

Pushed twice, finds the general entry

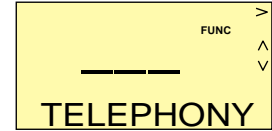
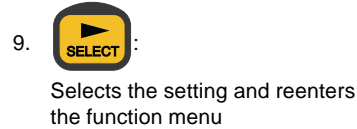
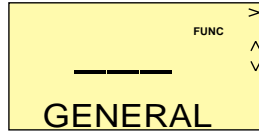

Enters the entry

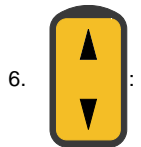
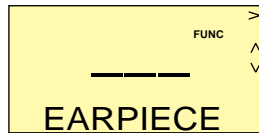
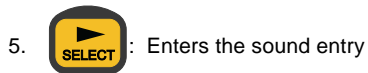
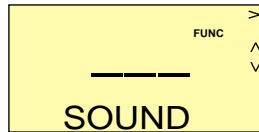
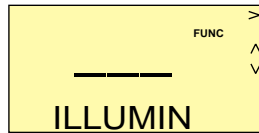

Pushed twice, finds the entry

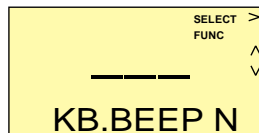
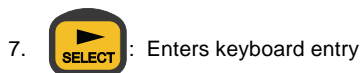
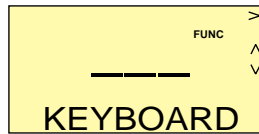

To activate the new settings, turn the handset off and then on again.

Function Menu Item Description

Path:	Data:	Description:
GENERAL\ILLUMIN\INDICATOR\LEVL_0-3	0-3	Light intensity of each indicator lamp dimmer level.
GENERAL\ILLUMIN\DISPLAY\DB_L_0-3	0-9	Light intensity of each display backlight dimmer level.
GENERAL\ILLUMIN\DIMMER\D_LEVL	0-3	Dimmer level when handset is turned on.
GENERAL\ILLUMIN\DIMMER\D_LEVL\DIMDIR	0-2	Dimmer level start direction (see diagram on next page).
GENERAL\ILLUMIN\KEYBOARD\SECS	0-20	Number of seconds that handset light is on after a key has been pushed.
GENERAL\ILLUMIN\KEYBOARD\SECS\D_LEVL	0-3	Dimmer level when any key has been pushed (provided number of seconds in item above is 1 or more)
GENERAL\SOUND\EARPIECE\NORM	0-15	Earpiece normal volume level when handset is turned on.
GENERAL\SOUND\EARPIECE\NORM\ALARM	0-15	Earpiece alarm volume level when receiving DSC call or intercom.
GENERAL\SOUND\LOUDSPEAK\NORM	0-15	Speaker normal volume level when handset is turned on.
GENERAL\SOUND\LOUDSPEAK\NORM\ALARM	0-15	Speaker alarm volume level when receiving DSC call or intercom.
GENERAL\SOUND\LOUDSPEAK\NORM\ALARM\EXT_SPK	0-3	Handset control of external speaker.
GENERAL\SOUND\LOUDSPEAK\NORM\ALARM\EXT_SPK\HO_SPK	0-1	Speaker state when handset is hooked off. Default on=1 or off=0.
GENERAL\SOUND\KEYBOARD\KBBEEP	"Y"/"N"	Keyboard key beep when pushing key.
GENERAL\SOUND\SIDETONE\ST ATT	0-3	Feedback level of microphone to earpiece (recommended setting=1).
SERVICE\TELEPHONY\CH+MODE\INPUTS	"Y"/"N"	Setup of number of input digits when changing VHF channel. Y = 3 digits, N = 2 digits

The dimmer start direction can be set up in three different ways:

Start direction 0:

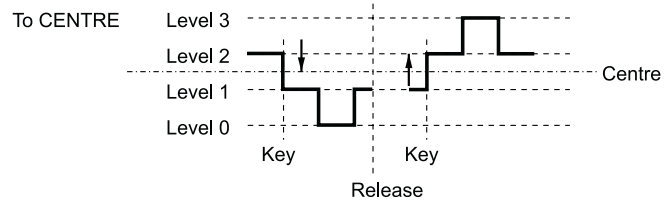

Start direction 1:

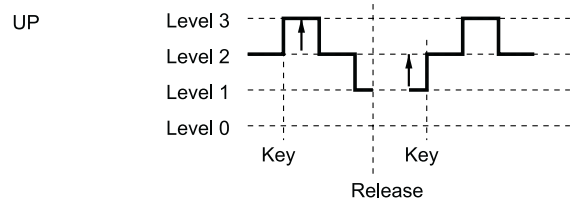

Start direction 2:

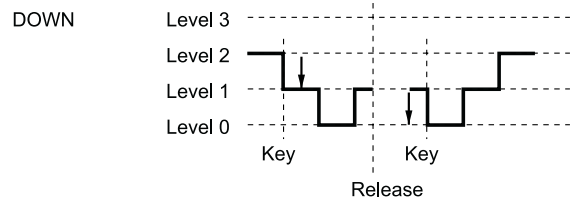

FUNcTION Menu Tree



Telephony	Scanner	Mem-no X	Name XXX	Pr-ch XX	Pr_sc X	
	Squelch	Mode X				
	Atis no	XXXXXXXXXX				
General	Illumin	Indicator	Levl_0 X	Levl_1 X	Levl_2 X	Levl_3 X
		Display	Levl_0 X	Levl_1 X	Levl_2 X	Levl_3 X
		Dimmer	D_levl X	D_dir X		
		Keyboard	Secs XX	D_levl X		
	Sound	Earpiece	Norm XX	Alarm XX		
		Loudspeak	Norm XX	Alarm XX	Extspk X	Ho spk X
		Keyboard	Beep X			
		Sidetone	St att X			
	Version	Handset	Software	XXXXXX	Serial no	XXXXXXXXXX
		Transceiv	Software	XXXXXX	Serial no	XXXXXXXXXX
Service	Code XXX	Bus setup	Handset	Loc_No X	Name XXX	
		Telephony	Ch_Mode	Inputs X		

VHF System Description

To the VHF system can be connected up to 7 control units. Each control unit has a unique location (1-7). If a control unit wants to control the transceiver, it has to be master of the system. The following describes the display read-outs shown in connection with different system priorities of the control units:

The control unit assigned location number 1 has the highest priority in the VHF system and is able to become master of the system at any time needed.

When more control units are connected to the VHF system, the main control unit has to be assigned location number 1.

When the system is free:

If a handset is in VHF mode, the display will show.



If a handset's function menu is active, the display shows the menu item.

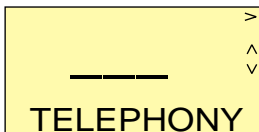

When a control unit is master of the system, the other control units, if in VHF mode, show the following display to indicate that the transceiver is in use by another control unit:

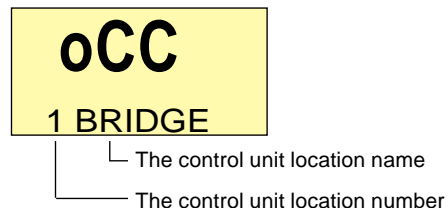

If the other control units' function menus are active, the display will show the menu item as usual.



Getting the MASTER priority in the system:

To operate the transmitter, the handset has to be master of the system. To become master of the system, simply hook off the handset.

When the handset becomes master of the system, the display will not change.

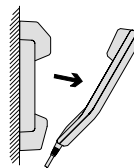

If the handset does not become master of the system and the handset is operated in VHF mode, the display will show the message:

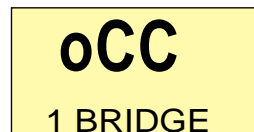

If the system is occupied by another control unit, hang up and wait for the system to become free.

International Channels

Channels	TX MHz	RX MHz	SIMPLEX		DUPLEX	
			Intership	Port	Port	Public
1	156,050	160,650			●	●
2	156,100	160,700			●	●
3	156,150	160,750			●	●
4	156,200	160,800			●	●
5	156,250	160,850			●	●
6	156,300	156,300	●			
7	156,350	160,950			●	●
8	156,400	156,400	●			
9	156,450	156,450	●	●		
10	156,500	156,500	●	●		
11	156,550	156,550		●		
12	156,600	156,600		●		
13	156,650	156,650	●	●		
14	156,700	156,700		●		
15	156,750	156,750	●	●		
16	156,800	156,800	Distress and calling			
17	156,850	156,850	●	●		
18	156,900	161,500			●	●
19	156,950	161,550			●	●
20	157,000	161,600			●	●
21	157,050	161,650			●	●
22	157,100	161,700			●	●
23	157,150	161,750			●	●
24	157,200	161,800			●	●
25	157,250	161,850			●	●
26	157,300	161,900			●	●
27	157,350	161,950			●	●
28	157,400	162,000			●	●

Channels	TX MHz	RX MHz	SIMPLEX		DUPLEX	
			Intership	Port	Port	Public
60	156,025	160,625			●	●
61	156,075	160,675			●	●
62	156,125	160,725			●	●
63	156,175	160,775			●	●
64	156,225	160,825			●	●
65	156,275	160,875			●	●
66	156,325	160,925			●	●
67	156,375	156,375	●	●		
68	156,425	156,425		●		
69	156,475	156,475	●	●		
70	156,525	156,525	DSC	DSC		
71	156,575	156,575		●		
72	156,625	156,625	●			
73	156,675	156,675	●	●		
74	156,725	156,725		●		
75	156,775	156,775		● L)		
76	156,825	156,825		● L)		
77	156,875	156,875	●			
78	156,925	161,525			●	●
79	156,975	161,575			●	●
80	157,025	161,625			●	●
81	157,075	161,675			●	●
82	157,125	161,725			●	●
83	157,175	161,775			●	●
84	157,225	161,825			●	●
85	157,275	161,875			●	●
86	157,325	161,925			●	●
87	157,375	157,375		● *)		
88	157,425	157,425		● *)		

Notes:

L) 1 W TX power.

*) Due to the introduction of the channels AIS1 at 161.975 MHz and AIS2 at 162.025 MHz for Automatic Identification System, channels 87 and 88 became simplex channels as of 1 January.

NB! The RX and TX frequencies can be read out on the control unit handset display by pressing (for more than one second) and holding the CH key.
At a front-operated VHF radio, the RX and TX frequencies can be displayed on a menu.

US Channels

Channels	TX MHz	RX MHz	SIMPLEX	DUPLEX
1	156,050	156,050	●	
2				B)
3	156,150	156,150	● !)	
4				B)
5	156,250	156,250	●	
6	156,300	156,300	●	
7	156,350	156,350	●	
8	156,400	156,400	●	
9	156,450	156,450	●	
10	156,500	156,500	●	
11	156,550	156,550	●	
12	156,600	156,600	●	
13	156,650	156,650	● L)	
14	156,700	156,700	●	
15		156,750	● RX)	
16	156,800	156,800	Distress and calling	
17	156,850	156,850	●	
18	156,900	156,900	●	
19	156,950	156,950	●	
20	157,000	157,000	●	
21	157,050	157,050	● !)	
22	157,100	157,100	●	
23	157,150	157,150	● !)	
24	157,200	161,800		●
25	157,250	161,850		●
26	157,300	161,900		●
27	157,350	161,950		●
28	157,400	162,000		●

Channels	TX MHz	RX MHz	SIMPLEX	DUPLEX
60				B)
61	156,075	156,075	● !)	
62				B)
63	156,175	156,175	●	
64	156,225	156,225	● !)	
65	156,275	156,275	●	
66	156,325	156,325	●	
67	156,375	156,375	● L)	
68	156,425	156,425	●	
69	156,475	156,475	●	
70	156,525	156,525	DSC	
71	156,575	156,575	●	
72	156,625	156,625	●	
73	156,675	156,675	●	
74	156,725	156,725	●	
75			B)	
76			B)	
77	156,875	156,875	● L)	
78	156,925	156,925	●	
79	156,975	156,975	●	
80	157,025	157,025	●	
81	157,075	157,075	● !)	
82	157,125	157,125	● !)	
83	157,175	157,175	● !)	
84	157,225	161,825		●
85	157,275	161,875		●
86	157,325	161,925		●
87	157,375	161,975		●
88	157,425	157,425	●	

Channels	WX	RX MHz
P1	WX1	162,550
P2	WX2	162,400
P3	WX3	162,475
P4	WX4	162,425
P5	WX5	162,450
P6	WX6	162,500
P7	WX7	162,525
P8	WX8	161,650
P9	WX9	161,775
P10	WX10	163,275

Notes:

- L) 1 W TX power. By pressing the 25W button in the US hook, the transmitter will transmit at 25W on channel 13 and 67, which are normally limited to 1W transmission.
- B) Channels 2, 4, 60, 62, 75 and 76 cannot be selected in US mode.
- !) Channels 3, 21, 23, 61, 64, 81, 82 and 83 may be legally used in certain instances, but they are not for use by the general public in US waters.
- RX) Only RX. Transmitter is blocked.
- NB!) The RX and TX frequencies can be read out on the control unit handset display by pressing (for more than one second) and holding the CH key.
At a front-operated VHF radio, the RX and TX frequencies can be displayed on a menu.

BI Channels

Channels	TX MHz	RX MHz	SIMPLEX		DUPLEX	
			Intership	Port	Port	Public
1	156,050	160,650			●	●
2	156,100	160,700			●	●
3	156,150	160,750			●	●
4	156,200	160,800			●	●
5	156,250	160,850			●	●
6	156,300	156,300	● L)			
7	156,350	160,950			●	●
8	156,400	156,400	● L)			
9	156,450	156,450	●	●		
10	156,500	156,500	● L)	● L)		
11	156,550	156,550		● L)		
12	156,600	156,600		● L)		
13	156,650	156,650	● L)	● L)		
14	156,700	156,700		● L)		
15	156,750	156,750	● L)	● L)		
16	156,800	156,800	Distress and calling			
17	156,850	156,850	● L)	● L)		
18	156,900	161,500			●	●
19	156,950	161,550			●	●
20	157,000	161,600			●	●
21	157,050	161,650			●	●
22	157,100	161,700			●	●
23	157,150	161,750			●	●
24	157,200	161,800			●	●
25	157,250	161,850			●	●
26	157,300	161,900			●	●
27	157,350	161,950			●	●
28	157,400	162,000			●	●

Channels	TX MHz	RX MHz	SIMPLEX		DUPLEX	
			Intership	Port	Port	Public
60	156,025	160,625			●	●
61	156,075	160,675			●	●
62	156,125	160,725			●	●
63	156,175	160,775			●	●
64	156,225	160,825			●	●
65	156,275	160,875			●	●
66	156,325	160,925			●	●
67	156,375	156,375	●	●		
68	156,425	156,425		●		
69	156,475	156,475	●	●		
70	156,525	156,525	DSC	DSC		
71	156,575	156,575		● L)		
72	156,625	156,625	● L)			
73	156,675	156,675	●	●		
74	156,725	156,725		● L)		
75	156,775	156,775		B)		
76	156,825	156,825		B)		
77	156,875	156,875	● L)			
78	156,925	161,525			●	●
79	156,975	161,575			●	●
80	157,025	161,625			●	●
81	157,075	161,675			●	●
82	157,125	161,725			●	●
83	157,175	161,775			●	●
84	157,225	161,825			●	●
85	157,275	161,875			●	●
86	157,325	161,925			●	●
87	157,375	157,375		● *)		
88	157,425	157,425		● *)		

Notes:

- B)** Channels 75 and 76 cannot be selected in BI mode.
- L)** 1W TX power on channels 6, 8, 10, 11, 12, 13, 14, 15, 17, 71, 72, 74, and 77.
- *)** Due to the introduction of the channels AIS1 at 161.975 Mhz and AIS2 at 162.025 MHz for Automatic Identification System, channels 87 and 88 became simplex channels as of 1 January 1999.
- NB!** - The ATIS function is enabled on all channels.
 - The RX and TX frequencies can be read out on the control unit handset by pressing (for more than one second) and holding the CH key.
 At a front-operated VHF radio, the RX and TX frequencies can be displayed on a menu.



S.P. RADIO A/S • Porsvej 2 • PO Box 7071 • DK-9200 Aalborg SV • Denmark
Phone: +45 9634 6100 • Fax: +45 9634 6101 • Telex: 69789 SPRAD DK
E-mail: sailor@sailor.dk • Web: www.sailor.dk